



## CENTRIFUGAL EXTRACT FAN

### APPLICATION

Ideal for air-extraction in small and medium size premises.

Powerful extract fans, designed to overcome the resistances of long ducting systems.

Units can be wall/panel and ceiling mounted: designed for surface or flush (plasterboard) installation through dedicated accessory on request.

### SPECIFICATION

**Casing** made of high quality ABS and polystyrene provides long lasting shock-proof and robust construction. The unit is finished in white RAL 9010 and are UV resistant.

**Forward curved centrifugal impeller**, providing enhanced aerodynamic properties, low noise and increased efficiency.

**Two-speed induction motor**, totally enclosed type, with integral thermal protection, mounted on sealed for life high quality ball bearings (30.000h), ideal for cool climate. Suitable for continuous and intermittent running.

### FEATURES & BENEFITS

IPX4 protection degree.

**Aesthetic front flat cover** for modern interior design easily removed for cleaning.

**Removable filter** in PP to protect the impeller and the motor. Easy to be removed for cleaning.

**Integral back-draught shutter** to prevent air flowing back into the room when the fan is off.

**Improved performance** thanks to the unique air straightener to optimise performance and reduce power consumption.

**Totally recyclable plastic components**, environmentally friendly.

**Double insulated:** no earth connection is required.

**Tested to the latest standards:** units are tested in the TÜV Rheinland recognised laboratory at Aerauliqa, meaning accurate, up to date information on electrical safety, performance and noise level that can be relied upon. Designed and manufactured in accordance with EN60335-2-80 (Low Voltage Directive) and the EMC Directive (Electromagnetic Compatibility).

### VERSIONS

#### Standard

The fan is operated via a separate ON/OFF switch or the light switch.

#### Run-on timer

The fan is equipped with a timer circuit adjustable from  $\pm 1'$  to 25'.

Operation: after switching off, the fan continues to run for the pre-set period of time.

#### Humidistat & timer

The fan is provided with an electronic circuit having a humidity sensor on board (adjustable from 50% to 95% RH) and a timer, adjustable from  $\pm 1'$  to 25'.

Operation: when the percentage of relative humidity is higher/lower than the pre-set threshold, the fan is automatically activated/deactivated. After switching off, the fan continues to run for the pre-set period of time.

## Installation

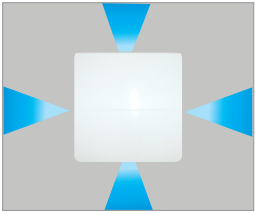

perimetral extraction

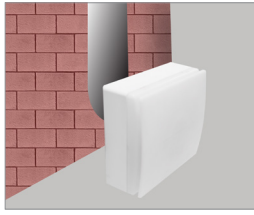

surface - wall/panel

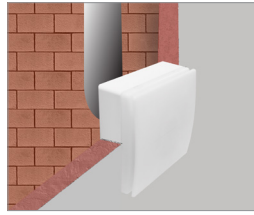

flush - panel

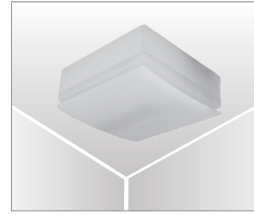

surface - ceiling

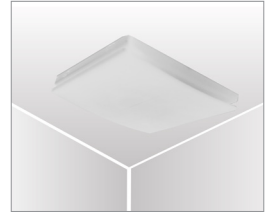

flush - ceiling

## Dimensions (mm) and Weight (kg)

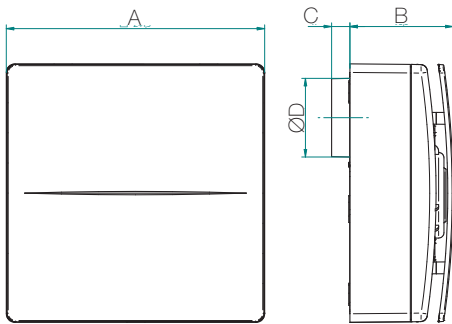

Model	QX80	QX100
A	241,5	241,5
B	96,5	96,5
C	17	17
ØD	73,5	96
Weight	1,87	1,87

## Performance curve

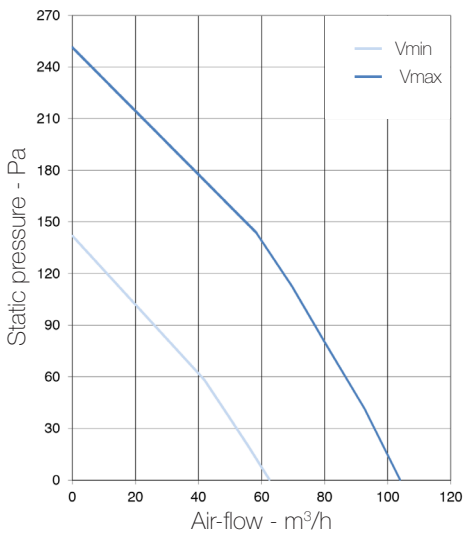

## Performances

Model	QX80	QX100
Air-flow m³/h max	104/62	104/62
Static pressure Pa max	251/142	251/142
Power consumption W max	28/17	28/17
Sound pressure dB(A) @ 3m <sup>(1)</sup>	38/27	38/27
Ambient temperature °C max	50	50
Marking	CE	CE

- 220-240V ~ 50/60Hz.
- air performance measured according to ISO 5801 a 230V 50Hz, air density 1,2 Kg/m³.
- data measured in the TÜV Rheinland recognised laboratory in Aeraulqa.
- (1) sound pressure level @ 3m in free field, for comparative purposes only.



www.tuv.com  
ID 0217007721